

DISTRIBUTED POWER WIRELESS CONTROL SYSTEM

ARC/DPWCS/V3.0 USER MANUAL



January 2018

RELEASE 1.0



Advanced Rail Controls Private Limited

Bangalore-560092

INDEX

INDEX NO.	CONTENTS	PAGE NO.
1.0	Introduction	1
2.0	DPWCS Equipment deposition	2
3.0	Location of DPWCS equipment's in Loco	3
3.1	DPWCS connection diagram	3
3.2	Equipment Level interconnection	4
4.0	Equipment level Explanation	4
4.1	Control & Communication Unit (CCU)	4
4.1.1	Mechanical Design details of CCU	4
4.1.2	Interface details of CCU	5
4.2	Brake Interface Unit (BIU)	6
4.2.1	Mechanical Design details of BIU	6
4.2.2	Interface details of BIU	7
4.3	Driver Interface Unit (DIU)	7
4.3.1	Mechanical Design details of DIU	8
4.3.2	Interface details of DIU	8
4.3.3	Operator controls of DIU	9
4.3.4	Individual keypad details PXY key pad	9
4.3.5	DPWCS Functional keypad	10
4.3.6	DDU Functional keypad	10
4.3.7	DPWCS Numerical keypad	10
5.0	DIU Screens	11
5.1	DDU mode	12
5.2	Password Screen	13
5.3	Self-test Screen	14
5.4	Zone selection Screen	14
5.5	Inauguration Screen	15
5.6	Master Screen	15
5.6.1	Wagon entry Screen -1	16
5.6.2	Wagon entry Screen -2	17
5.6.3	Wagon entry confirmation Screen	17
5.7	Inauguration Screen in master	18
5.8	Master Loco Home Screen	22
5.9	Inauguration Screen in slave	24
5.9.1	Slave Loco Home Screen	25
5.10	Screens in Master	26
5.10.1	Modes	26
5.10.2	Reboot	27
5.10.3	IND, IDLE, BRAKE, ISO, BK-OUT modes	28
5.10.4	Independent mode	29
6.0	Inauguration Procedures	30
7.0	System Fault Diagnose	31
8.0	Spare Items & Accessories	32
9.0	Contact Details	35

IMPORTANT NOTICE

This is a sophisticated microprocessor based equipment and can be serviced only by trained skilled personnel. Opening the equipment by any unauthorized person will make the warranty null and void

1.0 INTRODUCTION

This document describes the technical details of Distributed Power Wireless Control System (DPWCS) used in 3-Phase Electric Locomotives [of WAG9, WAG9H, WAP7 & WAP5 classes] being operated by Indian Railways. The DPWCS System is designed to increase the throughput of the railway line tremendously without much additional input. DPWCS operation enables heavy haul with minimum coupler forces. Under DPWCS scheme, locomotives are distributed at different points in a long train and controlled through wireless from the master, and slave locomotive crew can be eliminated, if desired.

DPWCS complete system consists:

1. Control & Communication Unit (CCU)
2. Brake Interface Unit (BIU)
3. Driver Interface unit (DIU)
4. Pressure Sensor Unit (PSU)

Glossary

Abbreviation	Comment
CCU	Control and Communication Unit
BIU	Brake Interface Unit
DIU	Driver Interface Unit
VCU	Vehicle Control Unit
RIB	Relay Interface Board
LED	Light Emitting Diode
PSB	Power Supply Board
CB	Controller Board
VCU	Vehicle Control Unit

2.0 DPWCS EQUIPMENT DIPOSITION

SL.No.	Name of the Equipment	Qty per Loco	Location	Function
1	Control & Communication Unit (CCU)	1	Machine room	Implements DPWCS logic. Connected to Radio, VCU through MVB, DIU and BIU
2	Brake Interface Unit (BIU)	2	CAB, below A9 brake control	Provides Loco Brake and Auto Brake functions through E70 in the slave locomotives. Connected to CCU and Faiveley's E70 Brake system & Auto Brake controller in cab
3	Driver's Interface Unit (DIU)	2	CAB	Implements Driver's Commands & Status Indication. Connected to MVB.
4	GPS Receiver	2	Roof	Provides the GPS coordinates of the current location of the locomotive. Connected to DIU.
5	Antenna	2	Roof	Transmission of telemetry & tele-command data from master to slaves and vice-versa. Connected to Radio through coaxial cable.
6	Pressure Sensor Unit (having 6 transducers)	1	CAB	Measures MR, BC1, BC2, BP, F P Pressure and A F. connected to CCU.
7	MVB Star Coupler PCB (inserted in Slot V of VCU1 & VCU2)	2	VCU1/VCU2	Providing MVB connectivity to CCU and DIU.
8	MCB	1	SB2	ON/OFF control of 110V DC power to the DPWCS

3.0 LOCATION OF DPWCS EQUIPMENTS IN THE LOCOMOTIVE

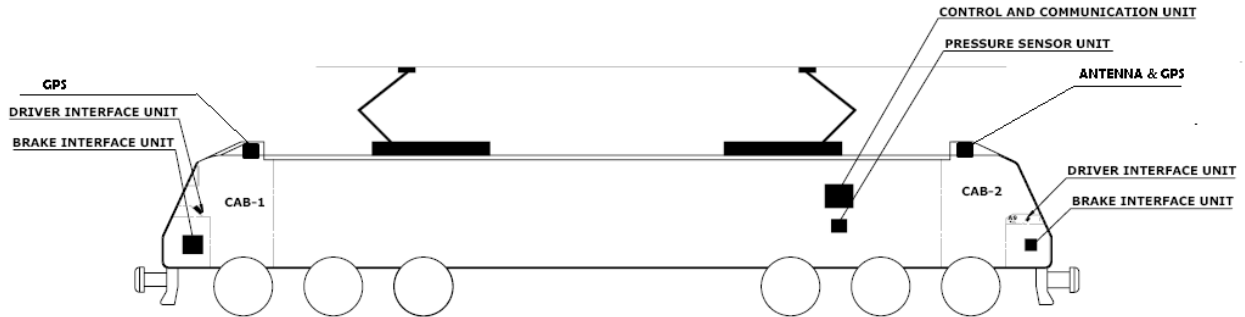

3.1 DPWCS EQUIPMENT CONNECTION DIAGRAM

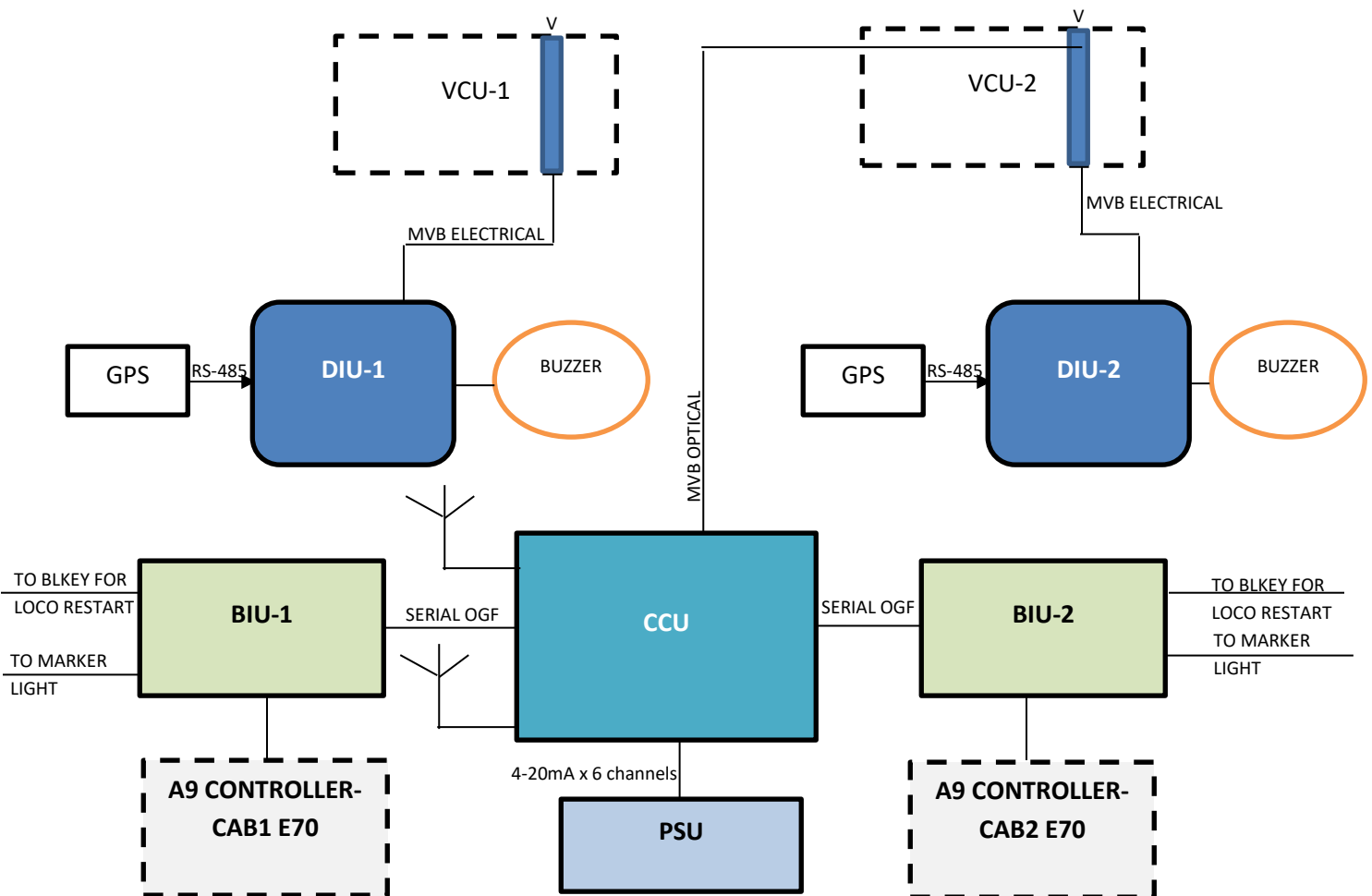

4.1.2 INTERFACE DETAILS OF CCU

Sl. No	Interface Details	Connector Type
1	Pressure Sensor	19 pin Circular Male connector
2	MVB	M20 x 1.5 Metal Gland to pass Optical cable
3	BIU1	M20 x 1.5 Metal Gland to pass Optical cable
4	BIU2	M20 x 1.5 Metal Gland to pass Optical cable
5	Ext.Fan	3 pin Circular Female connector
6	Power supply 110V DC	3 pin Circular Male connector
7	RS-485 CH1	9 pin D-SUB Male connector
8	RS-485 CH2	9 pin D-SUB Male connector
9	Service Port for Radio	9 pin D-SUB Female connector
10	Ethernet	M12 circular connector
11	Service Port for Debug	15 pin D-SUB Male connector
12	Antenna-1	M32 X 1.5 metal gland to pass UHF Radio co-axial cable
13	Antenna-2	M32 X 1.5 metal gland to pass UHF Radio co-axial cable

4.2 BRAKE INTERFACE UNIT

Brake Interface Unit interfaces the Faiveley E70 Brake Control system or Knorr Bremse CCB with DPWCS. It has micro-controller unit for carrying out various tasks. The signals from A9 controller are routed through the BIU using changeover switches. It has two modes viz. Master & Slave. When the locomotive works as Master, the changeover switches are thrown to A9 controller side so that the signals from A9 controller (potentiometer value referring to brake pipe pressure reference & 110V digital signals corresponding to handle position viz. release, run, initial application, full service and emergency) are connected directly to the E70 controller. Further, during Master mode, the BIU will be able to read both analog values and digital signals. The read values are sent to the slave over wireless for duplication in a similar way. In the slave loco, the BP pressure reference and A9 controller positions are received from Master over radio. The changeover switches in the BIU are switched to Slave mode, so that, A9 controller is isolated and the values are generated and injected by BIU into E70 controller. As the reference values are received from the master, the Slave will generate same braking effort and same braking conditions as that of master. BIU can cut off the BP valve in slave loco (to make the slave loco work as a wagon in the train - during radio signal loss conditions). In case of Knorr bromse brake controller, RS-485 signals will be connected to LON to RS-485 Interface box through CCU. BIU also implements the logic for remote loco restart. In case of any incipient problems with the slave loco, there may arise a need to restart the slave loco remotely from master. By activating the restart command from the DIU, remote loco gets re-started. For achieving this, the cab activating key (BL key) is interfaced with the BIU. When the loco is selected as Slave, the red marker light will automatically become ON. For this purpose, the red marker circuit is interfaced with BIU.

4.2.1 MECHANICAL DESIGN DETAILS OF BIU

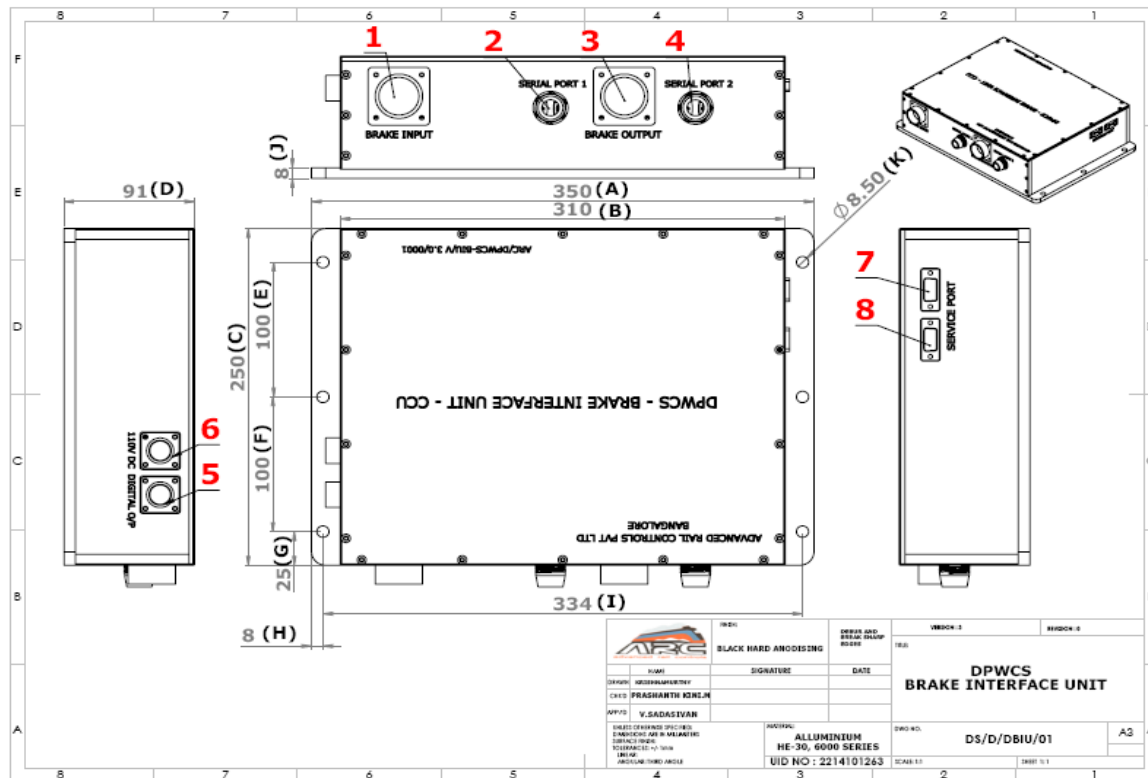

4.2.2 INTERFACE DETAILS OF BIU

Sl. No	Interface Details	Connector Type
1	Brake Input	19 pin Circular Male connector (In case of Faiveley E70 brake system)
2	Serial Port 1	M20 x 1.5 Gland to pass Optical cable
3	Serial Port 2	M20 x 1.5 Gland to pass Optical cable
4	Brake Output	19 pin Circular Female connector (In case of Faiveley E70 brake system)
5	Digital Output	10 pin Circular Female connector
6	Power supply 110V DC	3 pin Circular Male connector
7	Service Port for program	9 pin D-SUB Male connector
8	Service Port for Debug	9 pin D-SUB Female connector

4.3 DRIVER INTERFACE UNIT

The DIU is one of the key elements of DPWCS, as most of the operations can be carried out through DIU by the Driver. The DIU is designed in such a way that the same equipment can be used either in DPWCS fitted locomotives or in normal locomotives, by suitably selecting the mode of operation by the driver.

4.3.1 MECHANICAL DESIGN DETAILS OF DIU

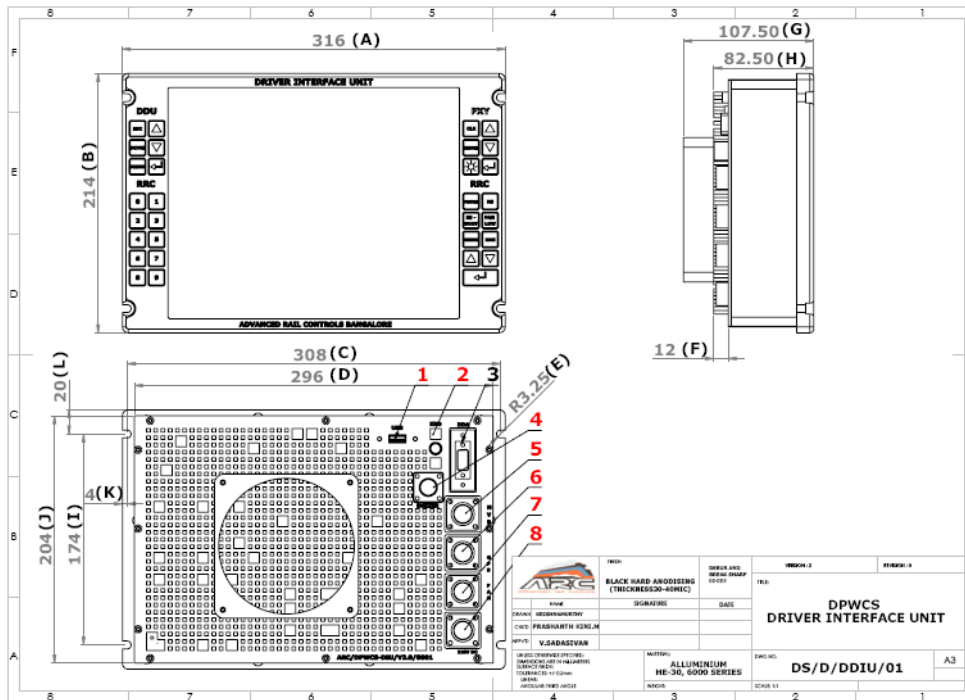

4.3.2 INTERFACE DETAILS OF DIU

Sl. No	Interface Details	Connector Type
1	USB	USB 2.0 PORT A
2	KBD	PS/2 Male
3	DDA	9 pin D-SUB Female connector
4	Buzzer	6 pin circular Male Connector
5	MVB	10 pin Circular Male connector
6	GPS	10 pin Circular Female connector
7	Ext.Fan	3 pin Circular Female connector
8	Power supply 110V DC	3pin Circular Male connector

4.3.3 OPERATOR CONTROLS OF DIU

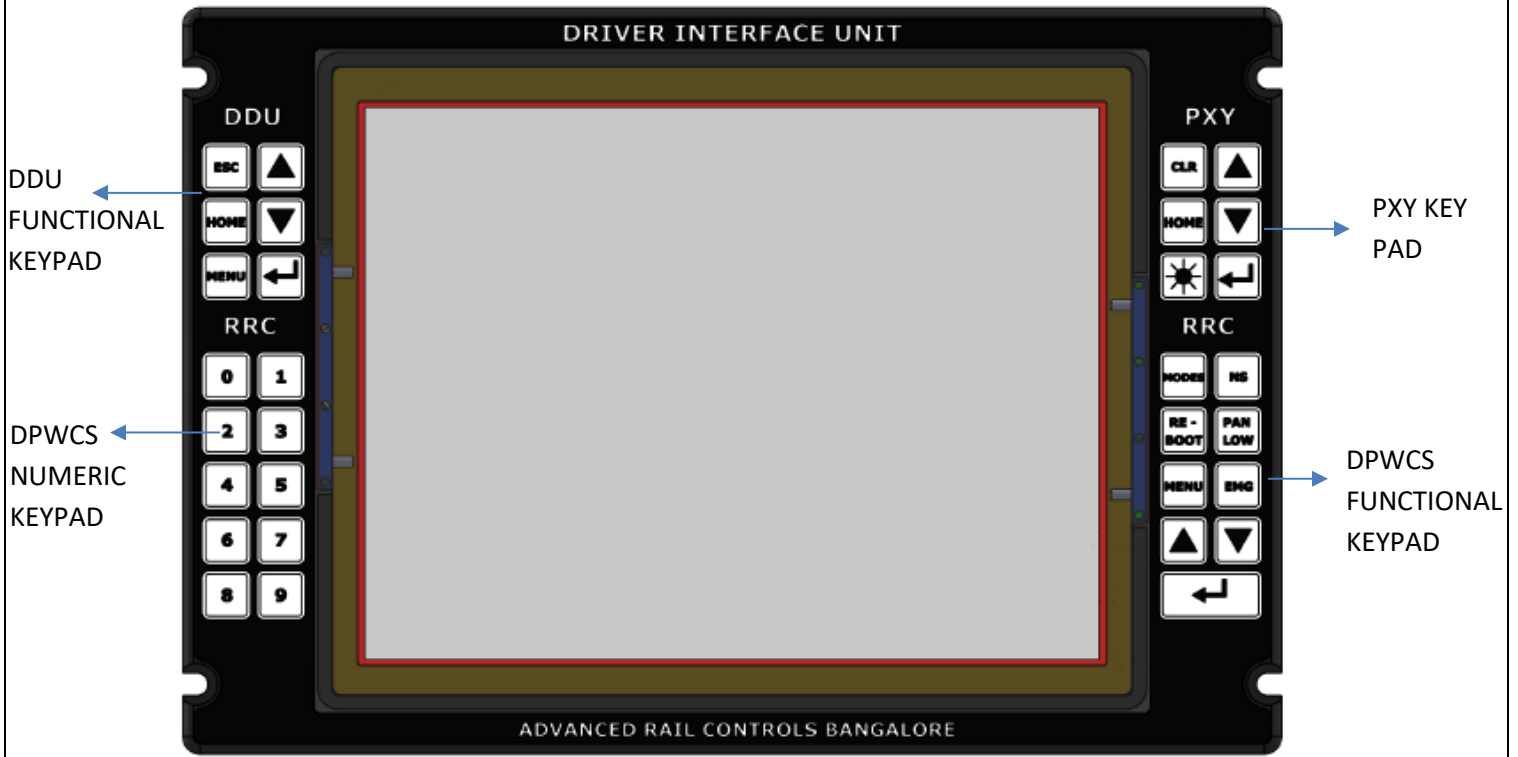

The DPWCS has a rugged membrane keyboard on the right-hand side and left-hand side. These keys are known as “PXY” keypad, “DPWCS Functional” keypad on the right-hand side, “DDU Functional” keypad and “DPWCS Numeric” keypad on the left-hand side. The “PXY” keypad has 6 keys, each assigned to a separate function, and the “DPWCS Functional” keypad has 9 keys, each assigned to a separate function. The “DDU Functional” keypad has 6 keys, each assigned to a separate function and the “DPWCS NUMERIC” keypad has 10 keys, each assigned to a separate numeric function.

4.3.4 INDIVIDUAL KEYPAD DETAILS: PXY KEY PAD

The PXY keypad has 06 membrane keys of rugged type. The keys are protected from direct ingress of dust and moisture. The keys are suitable for operation by fingers. The function assigned to each key is given below:

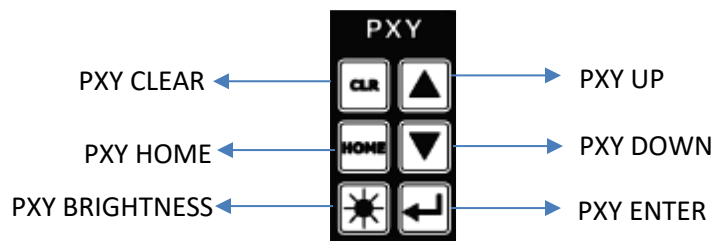

4.3.5 INDIVIDUAL KEYPAD DETAILS: DPWCS FUNCTIONAL PAD

The DPWCS Functional keypad has 09 membrane keys of rugged type. The keys are protected from direct ingress of dust and moisture. The keys are suitable for operation by fingers. The function assigned to each key is given below:

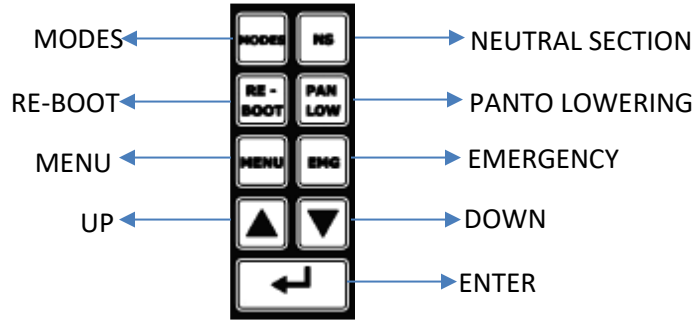

4.3.6 INDIVIDUAL KEYPAD DETAILS: DDU FUNCTIONAL KEYPAD

The DDU Functional keypad has 06 membrane keys of rugged type. The keys are protected from direct ingress of dust and moisture. The keys are suitable for operation by fingers. The function assigned to each key is given below:

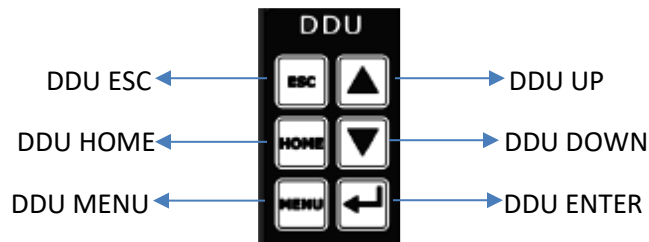

4.3.7 INDIVIDUAL KEYPAD DETAILS: DPWCS NUMERICAL KEYPAD

The DPWCS Numerical keypad has 10 membrane keys of rugged type. The keys are protected from direct ingress of dust and moisture. The keys are suitable for operation by fingers. The function assigned to each key is given below: (0-9).



5 DIU SCREENS

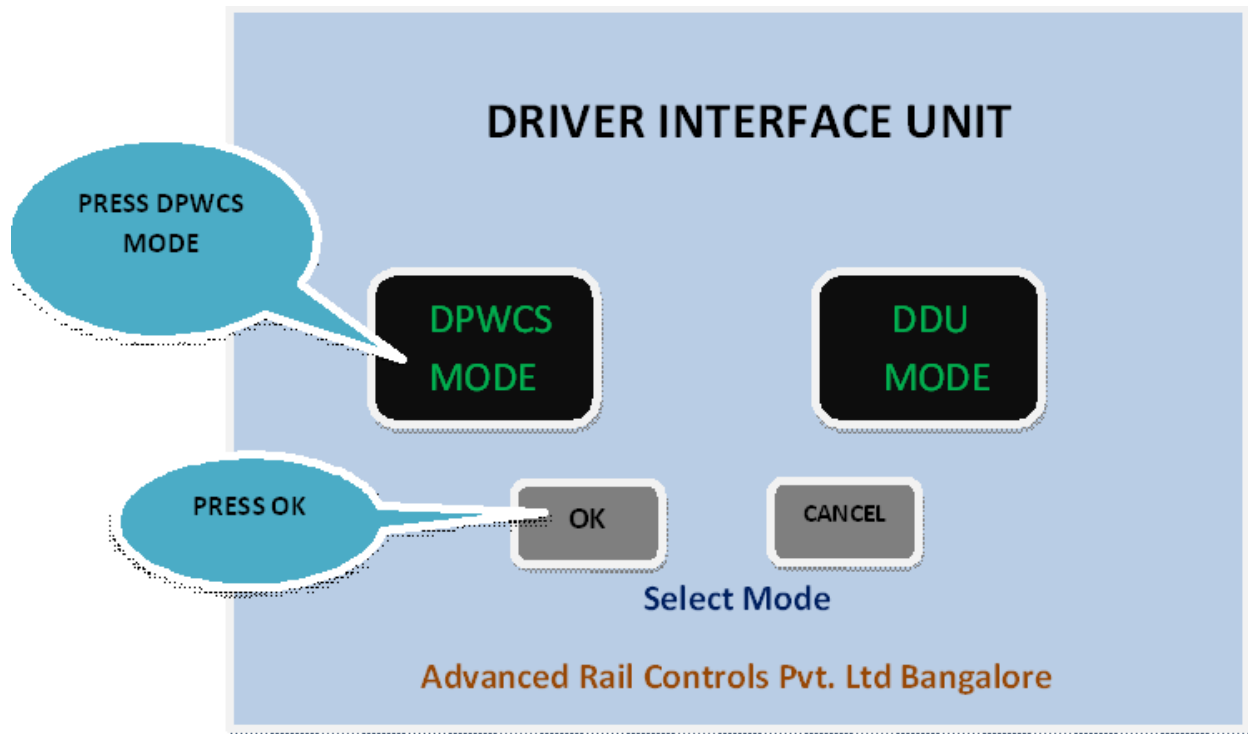

Above screen is the first screen in DIU (Driver Interface Unit) of DPWCS. This screen provides an option to select two modes viz. DPWCS Mode and DDU Mode. 'DPWCS mode' key enables the process of Radio remote control operations starting from password entry, inauguration process and displaying various parameters/data of all the locos connected in the DPWCS configured train. 'DDU mode' key enables normal loco operations displaying all the data of respective loco.

'OK' key confirms the Mode selection and the 'Cancel' key de-select the selected mode and gives one more chance to select the mode.

5.1 DDU MODE:



Note: All the DDU mode operations are explained in the 'driver's manual for DDU unit for three phase locomotives'

The only difference is that instead of external keys, soft keys (on touch panel) are provided on the display for navigation to different screens and pixy operation.

5.2 Password screen

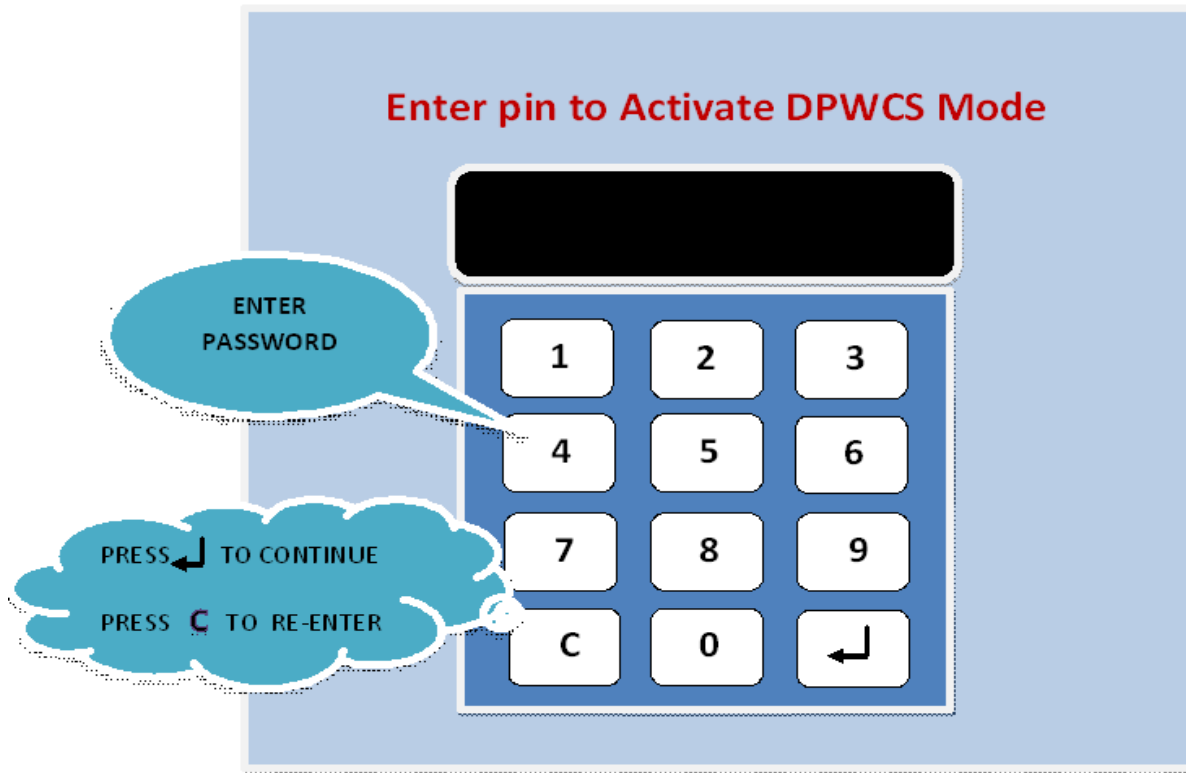

A 5-digit password has to be stored in the flash of the system. And entered password should match the stored password for further operation in RRC mode. After typing the password press “↵” key to confirm. If the password entered exceeds 5 digit a message should pop-up “Password Cannot Exceed 5 Digit” and if the password entered is wrong another message should pop up “Wrong Password Entered, Press ‘C’ and re-renter the Password”.

Once the password entered matches with the password stored next DPWCS screen will appear on the display.

5.3 Self-test screen

Below screen shows the healthiness of the system.



5.4 Zone Selection Screen

Different zone is having different range of frequency so press the zone to set desired frequency. The default frequency is 406.6MHz.

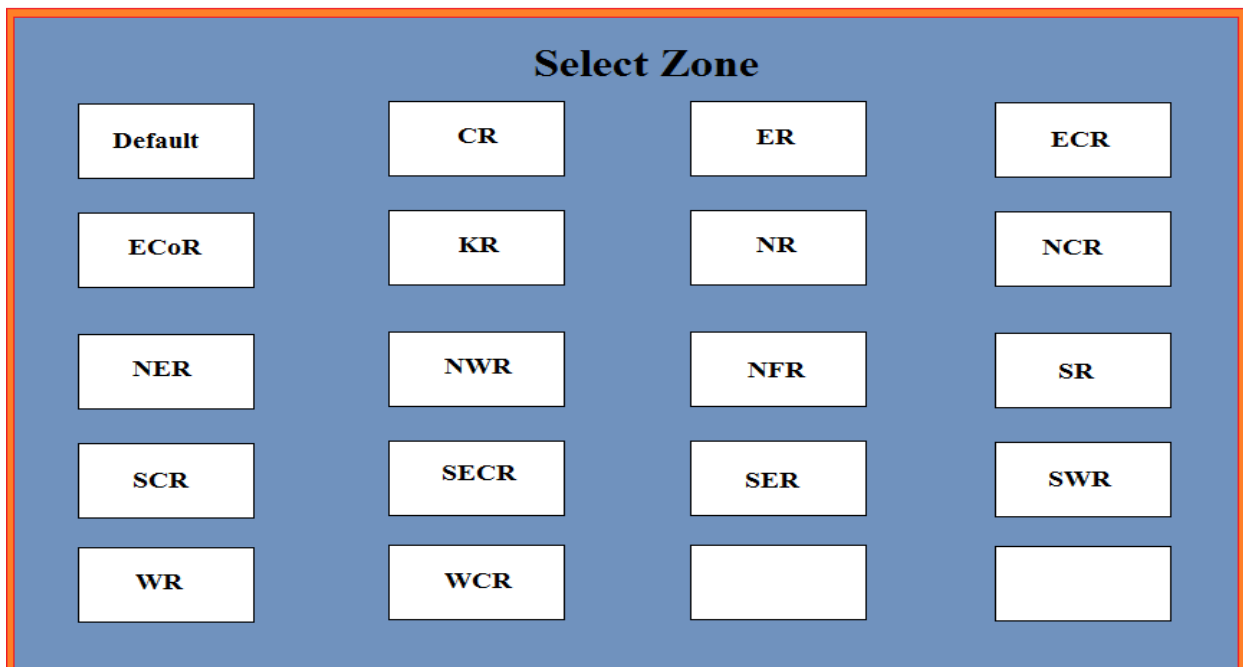

5.5 Inauguration Screen:

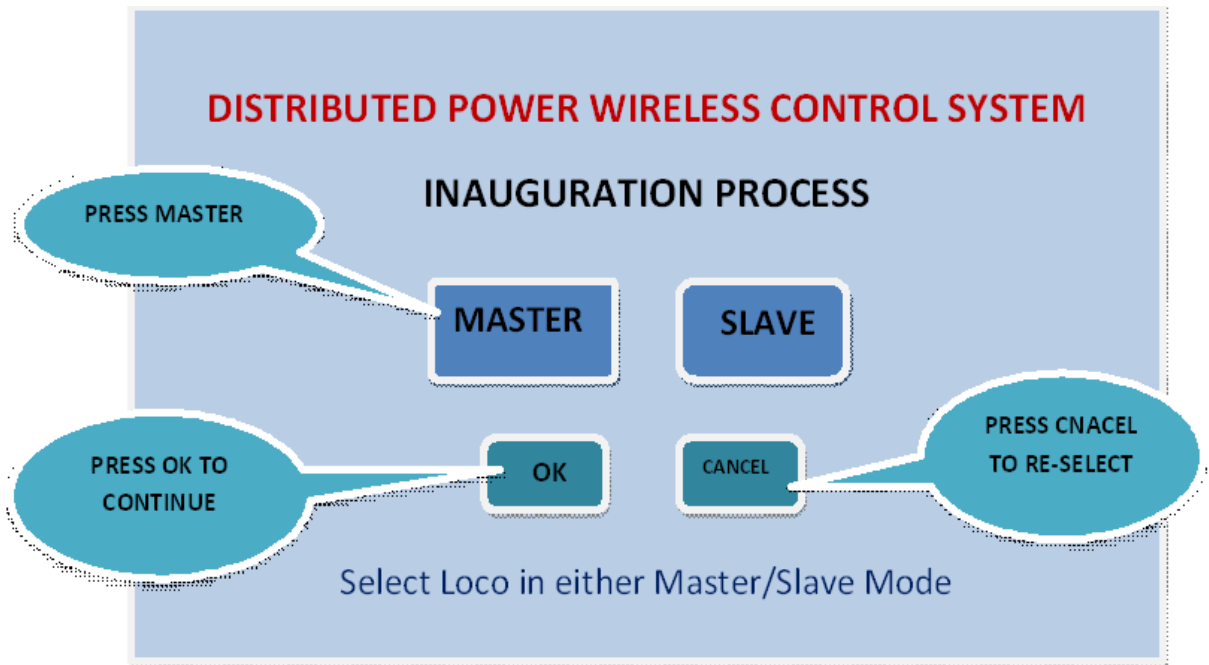

This is the first screen in the DPWCS mode which gives the option to select the loco as either **master** or **slave**. Select Master/Slave and then press '**OK**' to confirm. Else press '**CANCEL**' to re-select.

5.6 Master screen -1:

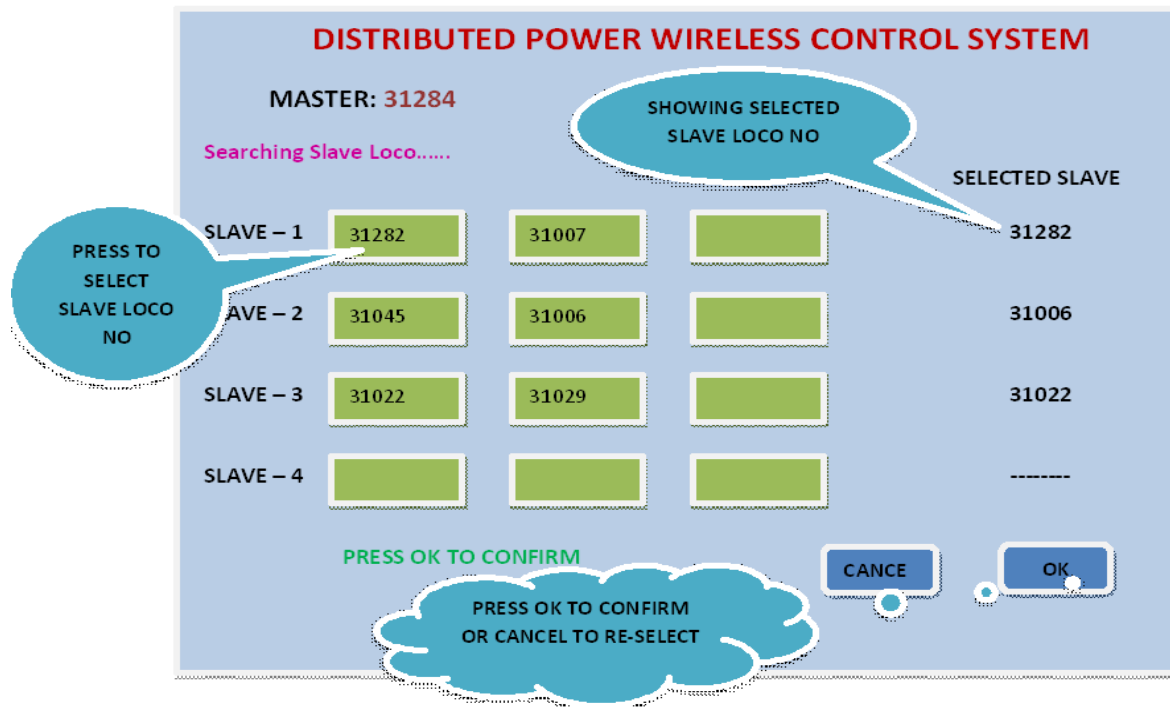

Once a loco is selected as master it starts searching for the slave locos. This screen displays all near slaves. Driver should select slave locos which are connected to same train. Once the slave is selected, selected slave loco no's are displayed for confirmation. Press 'OK' if the selected slave loco no's are correct else 'CANCEL' to re-select.

5.6.1 Wagon Entry screen -1:

In this screen Total train length is calculated. For that type of wagon and no. of wagons has to be entered. At first the data entered will be for Master to first slave (Slave-1).

1. Select any one type of wagon (**BOXN, BOB-N, N-BOY, TBT** etc) and enter the no. of wagons. And press "↵" key. Press ▲ or ▼ key to see the remaining type of wagons.
2. If more than one type of wagon needs to be entered, select another type and follow step '1'.
3. After entering all the data of wagons between master and first slave press 'Enter'.

This screen will also shows the information of No. of wagons entered and the total train length.

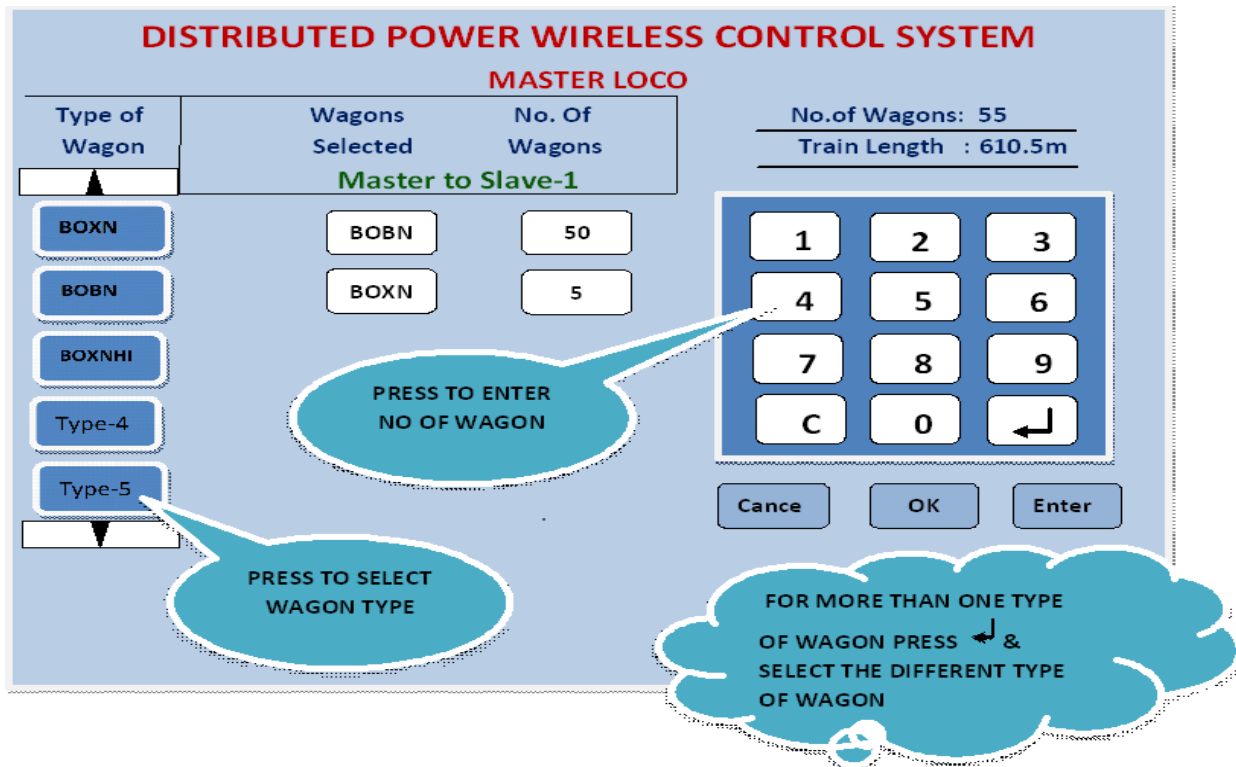

5.6.2 Wagon Entry screen -2:

DISTRIBUTED POWER WIRELESS CONTROL SYSTEM
MASTER LOCO

Type of Wagon	Wagons Selected	No. Of Wagons	
BOBN	BOBN	50	No. of Wagons : 55 Train Length : 610.5m
BOBN	BOBN	5	
BOXNH			
Type-4			
Type-5			

Master to Slave-1

BOBN
50

BOBN
5

1	2	3
4	5	6
7	8	9
C	0	↵

TRAIN HAS ONE MORE SLAVE..?

PRESS YES TO ENTER ONE MORE SLAVE WAGONS OR NO TO EXIT

PRESS TO NEXT SCREEN

PRESS TO ENTER ONE MORE SLAVE

After entering wagons press **Enter** then above screen will appear, asking “Train Has One more Slave..?” with options ‘YES’ and ‘NO’ keys. If no more slaves press **No** and press **OK** for next screen or press **YES** to re-enter wagons of one more slave.

5.6.3 Wagon Entry Confirmation Screen:

DISTRIBUTED POWER WIRELESS CONTROL SYSTEM
MASTER LOCO

No. of Wagons				Between each consist
Master to Slave-1	Slave-1 to Slave-2	Slave-2 to Slave-3	Slave-2 to Slave-3	Total Length Between each consist
55	57	--	--	
650	620	--	--	

Cross Verify the data you have entered. If correct press “ENTER” else press “BACK” to re-enter the data

BACK FOR RE-ENTER WAGONS OR ENTER FOR NEXT SCREEN

This screen displays total no. of wagons and total length between master and slave and between each slave. If the entered data is wrong press “**BACK**” key to go to **Wagon Entry Screen -1** to re-enter the wagon information data. Else press “**ENTER**” key to go to **Inauguration screen**.

5.7 Inauguration Screens in master

Inauguration starts by checking the communication. Once the communication with all system is established ‘BP drop check’ process starts. Once inauguration process is completed status of all the locos are displayed on the screen.

Inauguration Screen -1

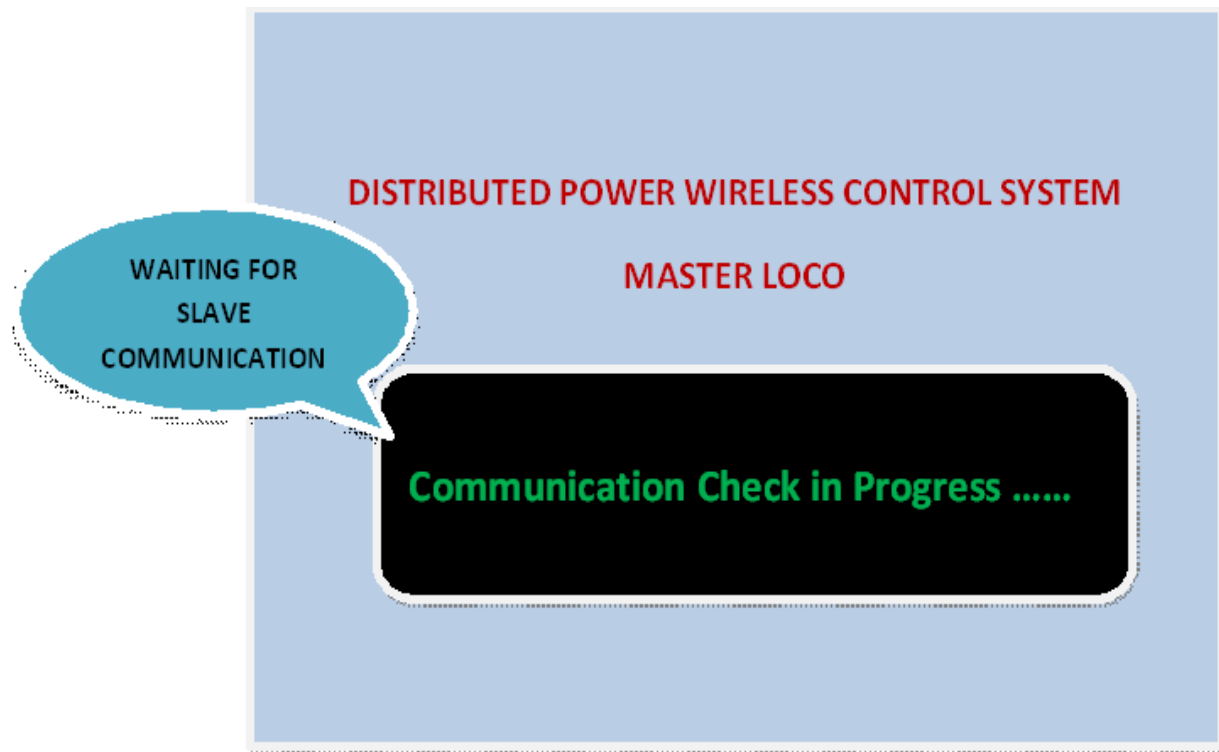

Inauguration screen -1 shows the status of communication check between master and slave locos. Once the communication is established between all the system ‘BP drop check’ is initialized. This is displayed in **Inauguration screen -2**. BP drop is done in the last slave of the train and the drop in BP has to be seen in all the other slaves and the master. **Inauguration screen -3** shows the BP continuity status and the actual BP value of all the locos. If BP continuity is obtained in all the locos than status message, “**BP Continuity OK**” will be displayed in front of respective slaves and the master.

Inauguration Screen -2

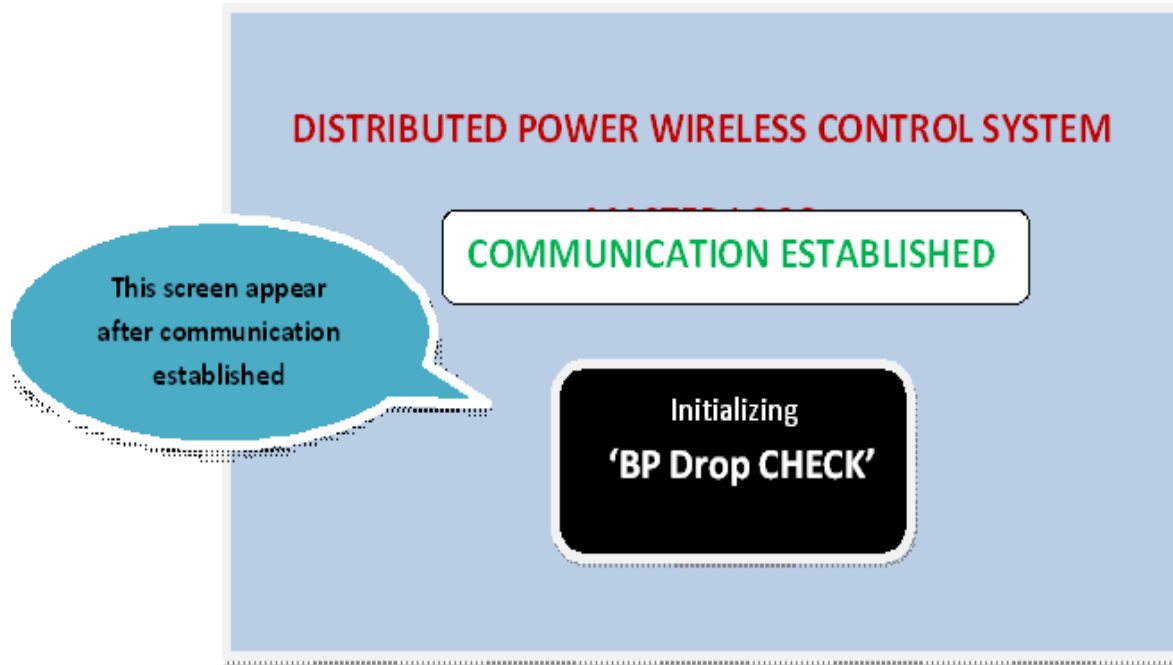

Inauguration Screen -3

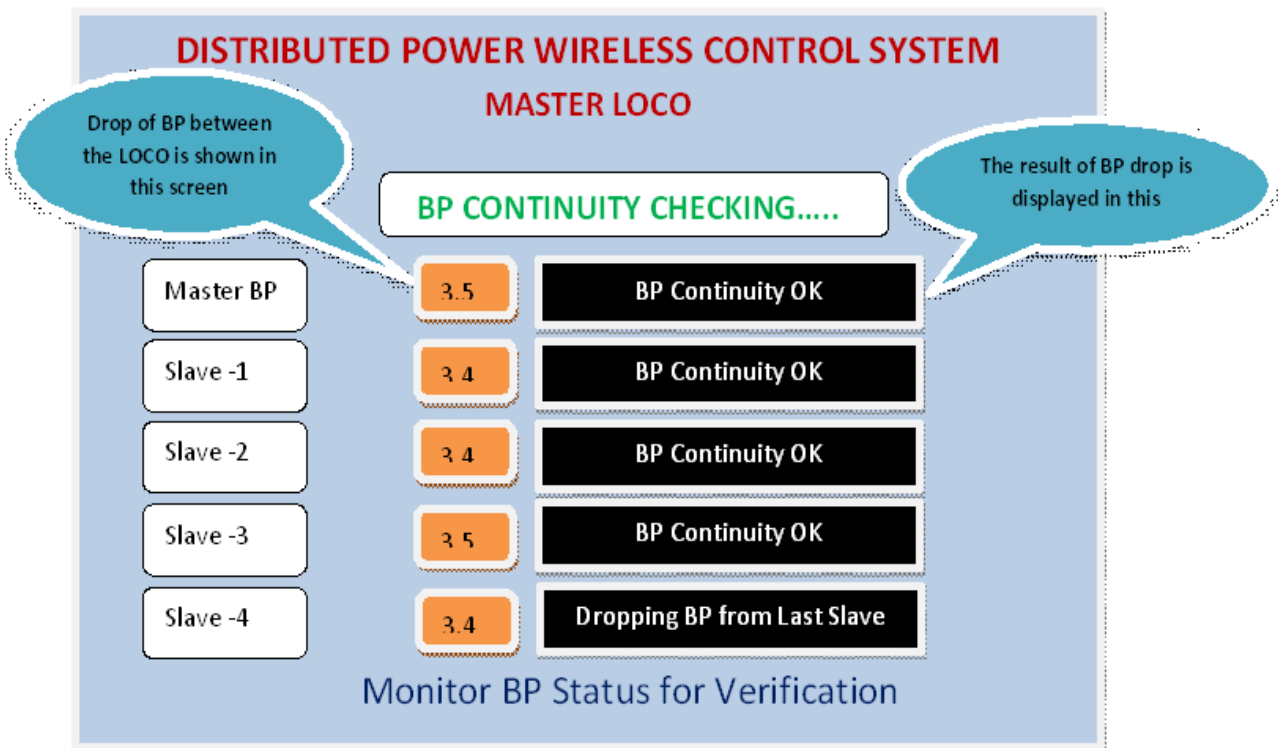

Inauguration Screen -4

If a wrong slave is selected during the inauguration process then BP continuity check will be failed. When there is no BP continuity a status message “BP Continuity FAILED” is displayed in-front of the wrongly selected slave.

RADIO REMOTE CONTROL
MASTER LOCO

BP CONTINUITY CHECKING.....

Master	3.	BP Continuity OK
Slave -1	3.	BP Continuity OK
Slave -2	5.	BP Continuity FAILED
Slave -3	3.	BP Continuity OK
Slave -4	3.	Dropping BP from Last

Monitor BP Status for Verification

Inauguration Screen -5

DISTRIBUTED POWER WIRELESS CONTROL SYSTEM
MASTER LOCO

BP CONTINUITY FAIL

INAUGURATION FAIL

One or more slave selected wrongly...

Please Re-enter the slave correctly and re- inaugurate

Failure of BP between the locos resulting this screen

Inauguration screen -5 displays the status message **“Inauguration Fail”** when BP continuity check fails telling driver to re-inaugurate. And the **Inauguration screen -6** shows successful inauguration message (**“Inauguration Successful”**) indicating inauguration process is completed.

Inauguration Screen -6

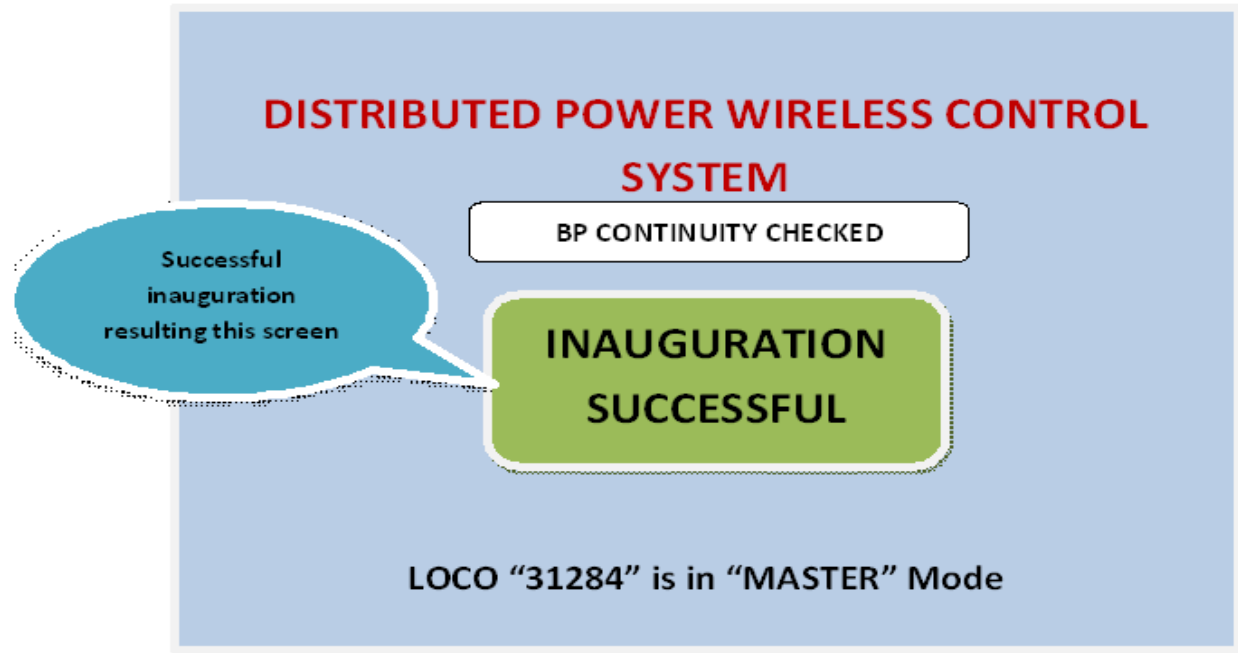

5.8 Master Loco Home screen:

SYN	Master	Slave-1	Slave-2	Slave-3	Slave-4
Loco No	31282	31284	31022		
Node	596	596	596		
Panto	Up	Up	Up		
VCB	On	On	On		
TE/BE	25	20	23		
Speed	5	5	5		
MR/FP	8.2/6	8.7/6	8.9/6		
BP	5.1	5.0	5.0		
BC1/BC2	0.0/0.0	0.0/0.0	0.0/0.0		
Parking B	6.2	6.1	6.1		
Airflow	6.0	6.0	6.0		

Buttons: MODES, REBOOT, NEUTRAL SECTION, PANTO LOW, MENU, Enter

Status message / Fault message of slaves/ sanding valve status

Main Menu: Loco No 31284

1. Vehicle Diagnostics
2. Information Train Bus
3. Process Information

Successful inauguration brings this screen with all locos parameters

This is the Home screen for Master Loco which displays the status of all the slave locos connected and also the status of master. Other than this it also displays the fault message of slave locos. Home screen has other options viz. MODES, REBOOT, NEUTRAL SECTION, PANTO LOW, MENU. And an enter key to confirm the selected option.

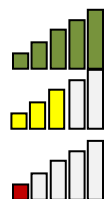

This indicates the **full** radio signal strength

This indicates the **medium** radio signal strength

This indicates the **Low** radio signal strength

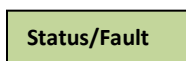

This box shows the status of the key pressed/fault messages/ or the error message of the RRC system and also the sanding valve status.

Slave Loco:

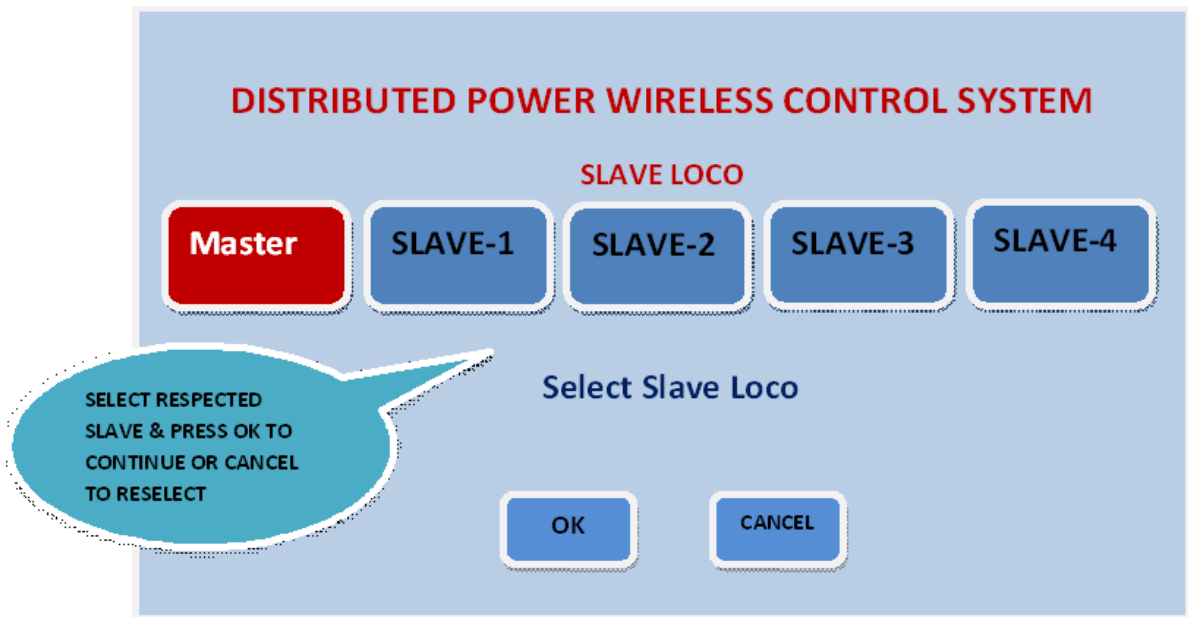
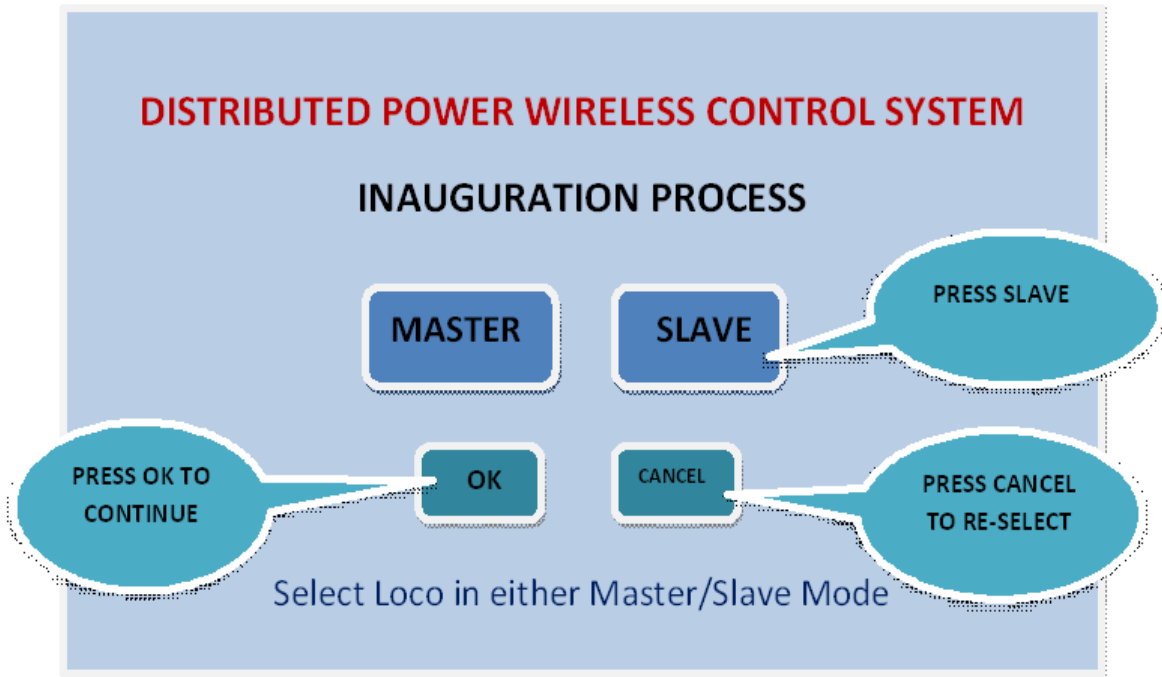

Once the loco is selected as slave loco we need to select the position of that loco in the train from **SLAVE – 1 to SLAVE – 4**. After selecting the position of the loco in the train press '**OK**' to confirm and press '**CANCEL**' to re-select the position of the loco in the train.

5.9 Inauguration Screens in SLAVE:

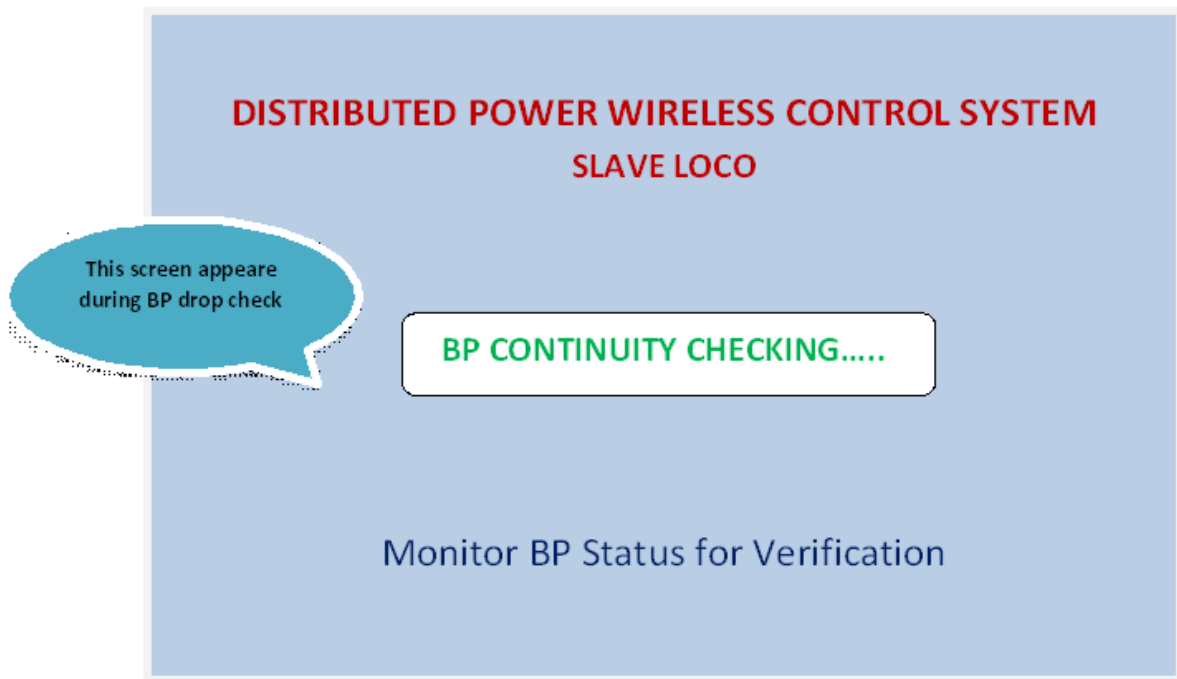
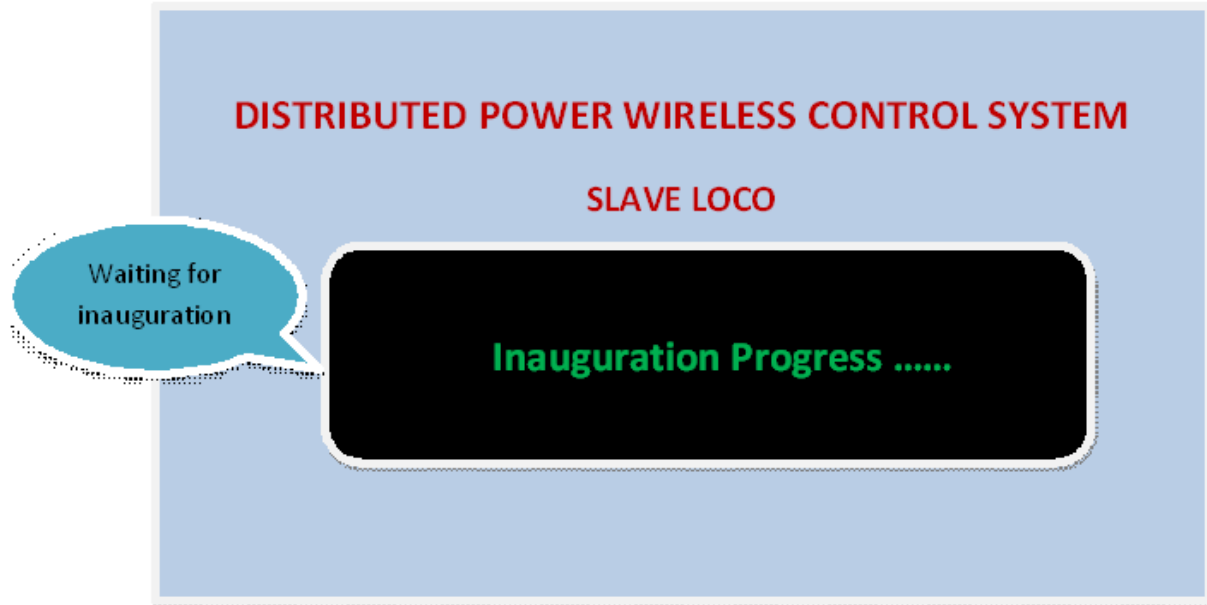

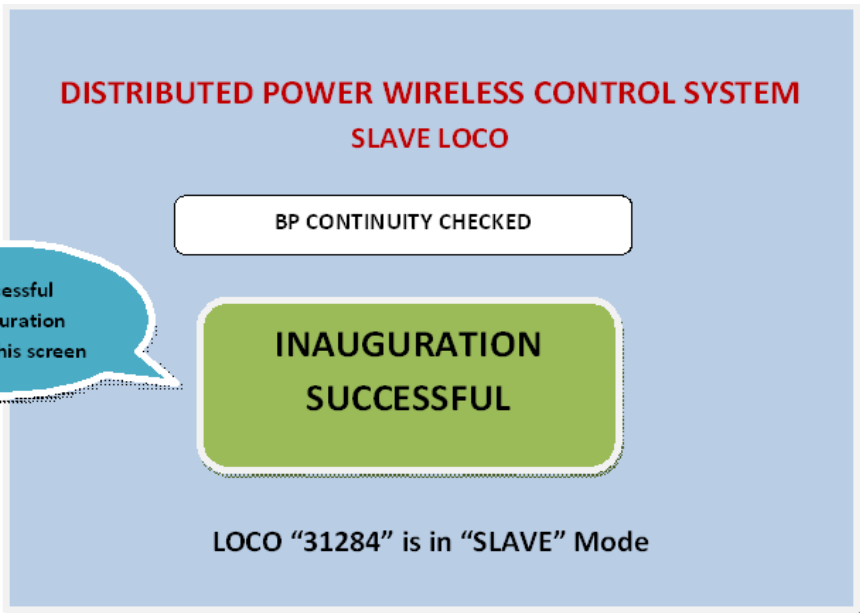

5.9.1 Slave Loco Home Screen:

After successful inauguration this will be the home screen for slave loco.

	Master	Slave-1	Slave-2	Slave-3	Slave-4
Loco No	31282	31284	31022		
Node	596	596	596		
Panto	Up	Up	Up		
VCB	On	On	On		
TE/BE	25	20	23		
Speed	5	5	5		
MR/FP	8.2/6	8.7/6	8.9/6		
BP	5.1	5.0	5.0		
BC1/BC2	0.0/0.0	0.0/0.0	0.0/0.0		
Parking B	6.2	6.1	6.1		
Airflow	6.0	6.0	6.0		

Main Menu:

- >1. Vehicle Diagnostics
- 2. Information Train Bus
- 3. Process Information

Loco No 31282

Buttons: Hom, CLR, Ente, Up, Down

5.10 Screens in Master:

5.10.1 Modes

SYN	Master	Slave-1	Slave-2	Slave-3	Slave - 4	MODES
Loco No	31282	31284	31022			SYNC
Node	596	596	596			IND
Panto	Up	Up	Up			BRAKE
VCB	On	On	On			IDLE
TE/BE	25	20	23			ISO
Speed	5	5	5			Bk-OUT
MR/FP	8.2/6	8.7/6	8.9/6			Enter
BP	5.1	5.0	5.0			HOME
BC1/BC2	0.0/0.0	0.0/0.0	0.0/0.0			
Parking B	6.2	6.1	6.1			
Airflow	6.0	6.0	6.0			
Status message / Fault message of slaves/ sanding valve status						Status/Fault
Main Menu:		Loco No 31284		↑ Hom CLR Ente ↓		
>1. Vehicle Diagnostics 2. Information Train Bus 3. Process Information						

5.10.2 Reboot:

SYN	Master	Slave-1	Slave-2	Slave-3	Slave - 4	Reboot
Loco No	31282	31284	31022			System
Node	596	596	596			Loco
Panto	Up	Up	Up			
VCB	On	On	On			
TE/BE	25	20	23			
Speed	5	5	5			
MR/FP	8.2/6	8.7/6	8.9/6			ESC
BP	5.1	5.0	5.0			Enter
BC1/BC2	0.0/0.0	0.0/0.0	0.0/0.0			HOME
Parking B	6.2	6.1	6.1			
Airflow	6.0	6.0	6.0			

Status message / Fault message of slaves/ sanding valve status

Status/Fault

Main Menu: Loco No 31284

>1. Vehicle Diagnostics

2. Information Train Bus

3. Process Information

Hom CLR Ente

5.10.3 IND, IDLE, BRAKE, ISO, BK-OUT Modes

SYN	Master	Slave-1	Slave-2	Slave-3	Slave - 4	IND -MODE
Loco No	31282	31284	31022			Slave-1
Node	596	596	596			Slave-2
Panto	Up	Up	Up			Slave-3
VCB	On	On	On			Slave - 4
TE/BE	25	20	23			ALL
Speed	5	5	5			ESC
MR/FP	8.2/6	8.7/6	8.9/6			Enter ↵
BP	5.1	5.0	5.0			HOME
BC1/BC2	0.0/0.0	0.0/0.0	0.0/0.0			
Parking B	6.2	6.1	6.1			
Airflow	6.0	6.0	6.0			

Status message / Fault message of slaves/ sanding valve status Status/Fault

Main Menu: Loco No 31284

- >1. Vehicle Diagnostics
- 2. Information Train Bus
- 3. Process Information

Hom CLR Ente

5.10.4 Independent Mode

In the independent mode selected independent loco parameters are displayed in red box indicating that the selected slave loco will work independently. And the Panto and VCB of the loco can be independently controlled by the keys given the below screen.

SYN	Master	Slave-1	Slave-2	Slave-3	Slave - 4	IND -MODE
Loco No	31282	31284	31022			Panto UP
Node	596	596	596			Panto Dn
Panto	Up	Up	Up			VCB On
VCB	On	On	On			VCB Of
TE/BE	25	20	23			ESC
Speed	5	5	5			Enter ↵
MR/FP	8.2/6	8.7/6	8.9/6			HOME
BP	5.1	5.0	5.0			
BC1/BC2	0.0/0.0	0.0/0.0	0.0/0.0			
Parking B	6.2	6.1	6.1			
Airflow	6.0	6.0	6.0			
Status message / Fault message of slaves/ sanding valve status						Status/Fault
Main Menu: Loco No 31284 >1. Vehicle Diagnostics 2. Information Train Bus 3. Process Information						↑ Hom CLR Ente ↓

6.0 Inauguration Procedures

Slave Procedure

1. Go to the trail locomotive and make the brake configuration of locomotive as lead loco.
2. Release the loco brake from both the cab (1&2).
3. Switch **ON** the DPWCS system MCB.
4. Put the **BL** Key to **D** position.
5. Wait for the **NODE** to become **504**.
6. After **NODE** reaches **504** Press **DPWCS** MODE in DIU.
7. Enter Password and press **OK**.
8. Select zone if applicable or press default zone.
9. Self test screen shows the healthiness of the system.
10. Initial stage failure of system is shown in DIU.
11. Successful Self test brings the **Master** or **Slave** selection screen.
12. Press **Slave** and Press OK to continue.
13. Select the slave position from slave one to slave four.
14. Put the **BL** Key in **OFF** position and remove.
15. Procedure 1 to 14 is common for all slave locomotives.

Master Procedure

16. Switch **ON** the **DPWCS** system **MCB**.
17. Put the **BL** Key to **D** position.
18. Wait for the **NODE** to become **504**.
19. After **NODE** reaches **504** Press **DPWCS** MODE in DIU.
20. Enter Password and press **OK**.
21. Select zone if applicable or press default zone.
22. Self- test screen shows the healthiness of the system.
23. Initial stage failure of system is shown in DIU.
24. Successful Self- test brings the Master or Slave selection screen.
25. Press **Master** and Press **OK** to continue.
26. Select the Slave loco by pressing slave loco number displayed on DIU.
27. Enter the wagons between the Master and respective slave locos.
28. Verify the calculated train length and number of wagons.
29. After verifying the Train length and number of wagons communication established screen will appear.
30. Raise the Panto and Close the VCB by giving driver command.

31. **BP** starts increasing up to 4.8kg in all locos that is master and slaves.
32. If BP fails to increase up to 4.8kg then check the drop of pressure between the locomotives.
33. Once **BP** increases to 4.8kg in all locos then BP drop test is carried out automatically.
34. Successful BP drop test results DPWCS home screen in all locos.
35. Wrong slave selection or failure of continuity results BP test failure screen.

7.0 System Fault Diagnose

DPWCS system having self-diagnose feature based on that we can find the exact reason behind the problem. After power ON MCB, DPWCS system checks its healthiness and result of self-test is displayed on driver interface unit. Self-test screen will dis appear if all system working fine or it struck on self-test screen itself.

Self-test screen



SELF TEST INCLUDED

1. Radio test.
2. Control Communication Unit test.
3. Driver interface unit MVB test
4. Brake Interface Unit 1 test.
5. Brake Interface Unit 2 test.
6. Pressure sensor test.

8.0 SPARE ITEMS & ACCESSORIES

DRIVER INTERFACE UNIT (DIU)			
SL.No.	Item name	UID NUMBER	Quantity /unit
1	Processor board, 800 MHz	1122131001	One
2	10.4" TFT Display with in-built touch screen (P-CAP) 800 X 600	1113141103	One
3	Power supply Board (70V DC to 137.5 V DC nominal 110V DC, protection against surge and short circuit)	331013160Q	One
4	MVB Controller Board with ESD+ physical medium	331013100A	One
5	12V DC Fan small	1115121101	One
6	12V DC Fan big	1115121501	
7	14 keys membrane key board	2220111206	One
8	3 pin Circular Connector Male	111215230C	One
7	3 pin Circular Connector Female	111215230E	One
8	10 pin Circular Connector Male	1112152335	One
9	10 pin Circular Connector Female	111215230D	One
10	6 pin Circular Connector Male	11121523DS	One

11	9 pin Sub-D Connector Female with coding plate	2212151699	One
11	Fully assembled Buzzer unit	331013100T	One
12	Fully assembled GPS box	331013100S	One
13	Hybrid MVB bus coupler card	3310131018	One

CONTROL & COMMUNICATION UNIT (CCU)			
SL.No.	Item name	UID NUMBER	Quantity /unit
1	ARM Controller Board	331013101B	One
2	UHF Radio	1127141102	One
3	Antenna	1110111203	Two
4	Co-axial cable- 10m	1112103027	Two
5	Power supply Board (70V DC to 137.5 V DC nominal 110V DC, protection against surge and short circuit)	331013101P / 331013101S	One
6	MVB Controller Board	331013101E	One
7	12V DC Fan Small	1115121101	One
8	12V DC Fan Big	1115121501	One
9	3 pin Circular Connector Male	111215230C	One
10	3 pin Circular Connector Female	111215230E	One
11	19 pin Circular Connector Male	11121523CG	Two
12	9 pin Sub-D Connector Male with coding plate	2212151671	Two
13	9 pin Sub-D Connector Female	111215235R	One
14	15 pin Sub-D Connector Male	1112151582	One
15	M12 Connector	111215237N	One
16	M20 X 1.5 Metal Gland	2216112521	Three

17	M32 x 1.5 Metal Gland	2216112603	Two
18	Pressure sensor Unit (6 sensors)	2228111811	One

BRAKE INTERFACE UNIT (BIU)			
SL.No.	Item name	UID NUMBER	Quantity /Unit
1	ARM Controller Board	331013101D	One
2	Relay Interface Board	331013100Y	One
3	Power supply Board (70V DC to 137.5 V DC nominal 110V DC, protection against surge and short circuit)	331013101P / 331013101S	One
4	12V DC Fan Small	1115121101	One
5	3 pin Circular Connector Male	111215230C	One
6	19 pin Circular Connector Male	22121523CP	One
7	19 pin Circular Connector Female	22121523CQ	One
8	M20 X 1.5 Metal Gland	2216112521	Two
9	9 pin Sub-D Connector Male	111215235R	One
10	9 pin Sub-D Connector Female	11121523CW	One
11	10 pin Circular Connector Female	111215230D	One

9.0 CONTACT DETAILS:

For any warranty/service related queries, please contact:

Bangalore HQ : Royapuram / Erode / Kalyan / Vadodara sheds
Mr.M.Mariappa, Head, Service Department, Advanced Rail Controls Private Limited, # 59/1&2, Above Bank of India, G-Block, Sahakaranagar, Bangalore-560 092 Phone : +91 80 42401212, +91 80 42401226 Fax: +91 80 42401213 Cell : + 91 9743715600 E-Mail: < mail@arc.net.in >, <mariappa@arc.net.in> URL : <www.arc.net.in>
Lallaguda / Vishakhapatnam / Kazipet / Vijayawada
Bharadwaj K.S [Base Station : Lallaguda] Cell : + 91 9553776172
CLW / Dankuni
Rahul Deo Sharma [Base Station : Chittaranjan] Cell : + 91 9334804107
Piyush Prasad [Base Station : Chittaranjan] Cell : + 91 9386203249
Ajni / Itarsi / Bhusawal / Bhopal / New Katni
Pankaj Ramesh Rao Hedau [Base Station : Nagpur] Cell : + 91 9021090829
Ghaziabad / Tuglakabad / RDSO

Subhash [Base Station : New Delhi]
Cell : + 91 9212846380

Tatanagar / Bandamunda

Vivek Kumar Mukhi [Base Station : Tatanagar]
Cell : + 91 7762905971

Gomoh / Howrah / Kancharapara

Ravikumar Vishwakarma [Base Station : Gomoh]
Cell : + 91 7050029319